

SUN2000 (8KTL-28KTL)

Quick Installation Guide

Issue 09
Date 2014-09-20

Copyright © JD Auspice Co., Ltd 2015. All rights reserved.

No part of this document may be reproduced or transmitted in any form or by any means without prior written consent of JD AUSPICE Co., Ltd.

Trademarks and Permissions

All other trademarks and trade names mentioned in this document are the property of their respective holders.

Notice

The purchased products, services and features are stipulated by the contract made between JDA and the customer. All or part of the products, services and features described in this document may not be within the purchase scope or the usage scope. Unless otherwise specified in the contract, all statements, information, and recommendations in this document are provided "AS IS" without warranties, guarantees or representations of any kind, either express or implied.

The information in this document is subject to change without notice. Every effort has been made in the preparation of this document to ensure accuracy of the contents, but all statements, information, and recommendations in this document do not constitute a warranty of any kind, express or implied.

JD Auspice Co., Ltd.

Website: <http://www.jdauspice.com>

Email: service@jdauspice.com

1. Overview

Personnel Requirements

- Only qualified and trained electrical technicians are allowed to operate the SUN2000.
- Operation personnel should understand the composition and working principles of the PV grid-tied power system and local regulations.

Identification Protection

- The signs on the SUN2000 shell specify important information about secure operation. Do not damage the signs.
- The nameplate attached to the SUN2000 side panel lists the SUN2000 parameter information. Do not damage the nameplate.

Installation



NOTICE

Before installation, read this document carefully. JDA shall not be liable for any consequence caused by violation of the regulations specified in this document.

-
- Before installing the SUN2000, ensure that the SUN2000 is not connected or electrified.
 - To ensure good heat dissipation and reserve enough space for installing the SUN2000, the SUN2000 is at least 200 mm, 500 mm, 600 mm, and 1000 mm away from objects on its both sides, top, bottom, and front respectively.
 - Install the SUN2000 in environments with good ventilation to ensure system performance.
 - Ensure that the SUN2000 heat sinks are unblocked.
 - Do not move the components inside the shelf except the wiring terminals at the bottom.

Electrical Connection



DANGER

Before connecting cables to the SUN2000, ensure that the SUN2000 is intact and secure. Otherwise, electrical shocks or fire may be triggered.

-
- Before connecting cables to the SUN2000, shield the PV modules by using opaque cloth.
 - All electrical connections must comply with local laws and regulations.
 - Before using the SUN2000 to generate electricity in grid-tied mode, obtain approval from the local power supply department.
 - Ensure that the cables to the solar power system are properly connected and insulated (That is, the insulation resistance between the ground and the main loop formed by PV

module strings, the SUN2000, and protective devices is less than 1 Mohm.) and meet specifications.

Operation



DANGER

High voltages may cause electrical shocks and death during SUN2000 operation. Strictly comply with the safety precautions in this document and associated documents when operating the SUN2000.

- Do not disconnect the DC power supply during the SUN2000 operation.
- Do not touch a running SUN2000 except for the liquid crystal display (LCD) and DC switch because the shelf and heat sinks become hot during the SUN2000 operation.
- Only professionals are allowed to set initialization parameters during the first power-on of the SUN2000. Incorrect settings may affect the SUN2000 operation and cause the SUN2000 to conflict with local certification.
- Keep an over 20 cm distance away from the SUN2000 because radiation is generated during the SUN2000 operation.
- When operating the SUN2000, follow local laws and regulations.









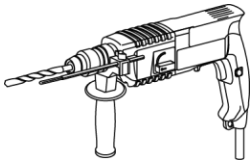

Maintenance and Replacement

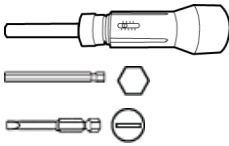
- Before any maintenance, power off the SUN2000 based on the power-off guidelines and then wait for at least 5 minutes.
- Stand temporary warning signs or fences to prevent unauthorized personnel to enter the maintenance site.
- Rectify the faults that compromise the SUN2000 security performance before restarting the SUN2000.
- A faulty SUN2000 requires overall maintenance. Contact the dealer if any fault occurs inside the SUN2000.
- Maintain the SUN2000 after you get familiar with this document and tools and testing equipment are prepared.
- When maintaining the SUN2000, wear ESD gloves and comply with ESD precautions.

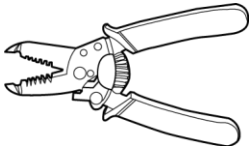
2. Installation and Maintenance Tools

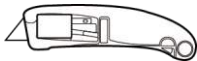
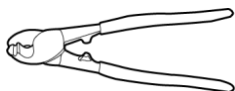
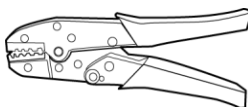
Prepare tools required for installation and electrical connections.

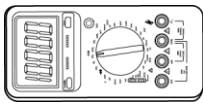
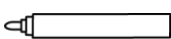
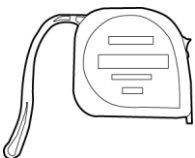
SUN2000 (8KTL-28KTL)
Quick Installation Guide

<p>Hammer drill</p>  <p>With a drill bit of $\Phi 14$</p>	<p>Adjustable wrench</p>  <p>With an open end of larger than or equal to 32 mm</p>	<p>Torque screwdriver</p>  <ul style="list-style-type: none"> Hexagon socket head: 5 mm Flat head: M6
<p>Flat-head screwdriver</p>  <p>3x100</p> <ul style="list-style-type: none"> Head width: 3-3.5 mm Pole length (excluding the handle): at least 100 mm Large handle 	<p>Socket wrench</p>  <p>With an open end of 10 mm</p>	<p>Diagonal pliers</p>
<p>Wire stripper</p>  <p>Applies to cables with cross-sectional areas of 4 mm², 6 mm², and 10 mm²</p>	<p>Rubber mallet</p> 	<p>Utility knife</p> 
<p>Cable cutter</p>  <p>Applies to cables with cross-sectional areas of 4 mm², 6 mm², and 10 mm²</p>	<p>Crimping tool</p>  <p>H4TC0001 Manufacturer: AMPHENOL</p>	<p>RJ45 crimping tool</p>
<p>Removal tool</p>  <p>H4TW0001 Manufacturer: AMPHENOL</p>	<p>Vacuum cleaner</p> 	<p>Multimeter</p> 
<p>Marker</p>  <p>Diameter: 10 mm at most</p>	<p>Measuring tape</p> 	<p>Level</p> 

SUN2000 (8KTL-28KTL)
Quick Installation Guide

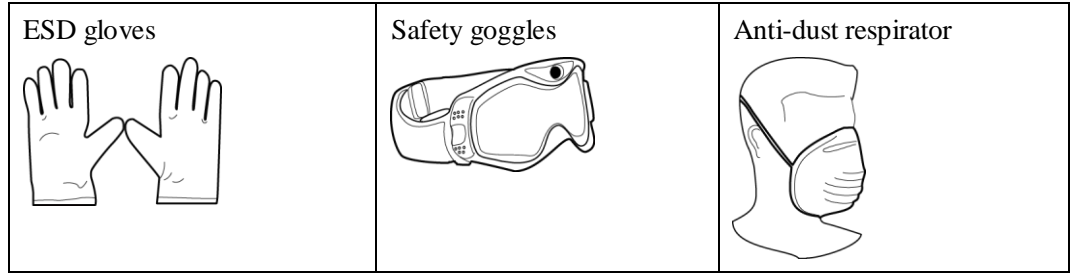

3. Moving the SUN2000

Step 1 Insert hands into the slots on both sides of the SUN2000 and hold the handles, as shown in [Figure 1-1](#) and [Figure 1-2](#). Two persons are required to move the SUN2000.

Figure 1-1 Moving the SUN2000 (1)

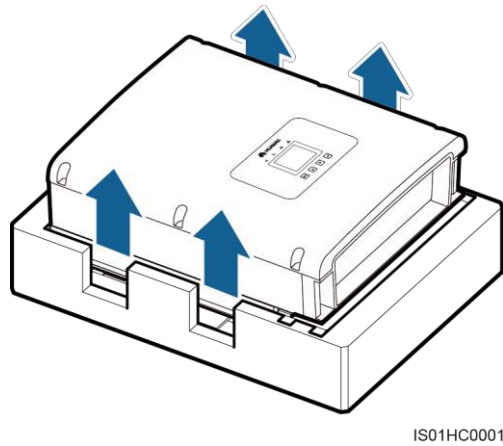
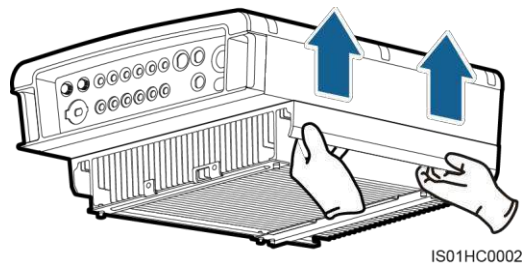

Figure 1-2 Moving the SUN2000 (2)



Step 2 Lift the SUN2000 from the packing case and move it to the installation position.



NOTICE

- To prevent device damage and personal injury, keep balance when moving the SUN2000 because the SUN2000 is heavy.
 - Do not put the SUN2000 with its wiring terminals contacting the floor because the power ports and signal ports are not designed to support the weight of the SUN2000. Place the SUN2000 horizontally.
 - When placing the SUN2000 on the floor, put foam or paper under the SUN2000 to protect its shell.
-

---End

4. Installing the SUN2000



NOTE

If the installation location is near the ground, first connect the PGND cable to the ground before installing the SUN2000 on the wall. For details, refer to [5 Connecting PGND Cables](#).

Step 1 Install the rear panel.

1. Determine the positions for drilling holes using the rear panel in the packing case, and mark the hole positions using a marker, as shown in [Figure 1-3](#).

Figure 1-3 Hole positions and dimensions

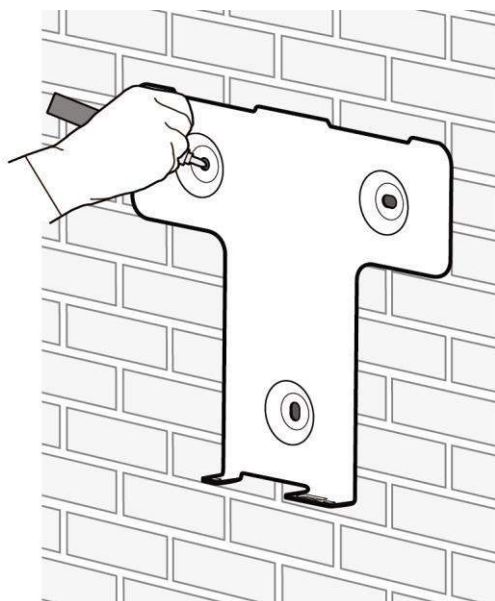

IS01SC0020

To ensure good heat dissipation and reserve enough space for installing the SUN2000, the SUN2000 is at least 200 mm, 500 mm, 600 mm, and 1000 mm away from objects on its both sides, top, bottom, and front respectively, as shown in [Figure 1-4](#).

Figure 1-4 Minimum installation clearance

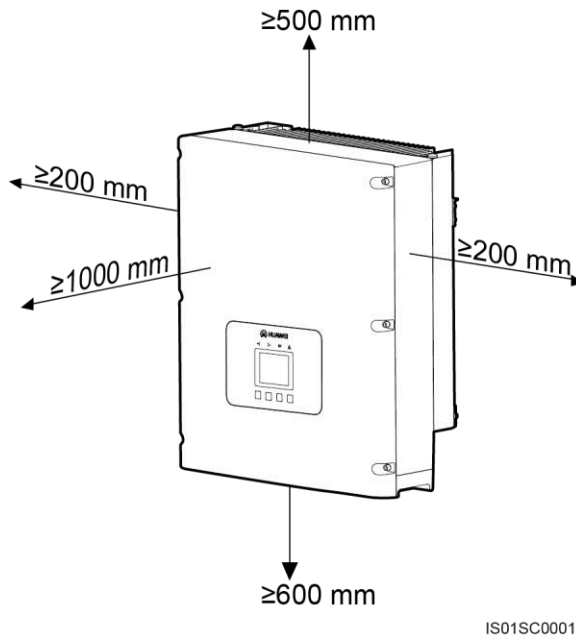

NOTE

The minimum installation clearance shown in [Figure 1-4](#) should be reserved in any installation scenarios, including the wall-mounted and support-mounted scenarios.

When installing multiple SUN2000s, install them in the same line if sufficient space is available and install them in triangle mode shown in [Figure 1-5](#). If no sufficient space is available, the stacked installation mode shown in [Figure 1-6](#) is not recommended. The clearance between SUN2000s meets requirements shown in the following figures.

Figure 1-5 Triangle installation mode

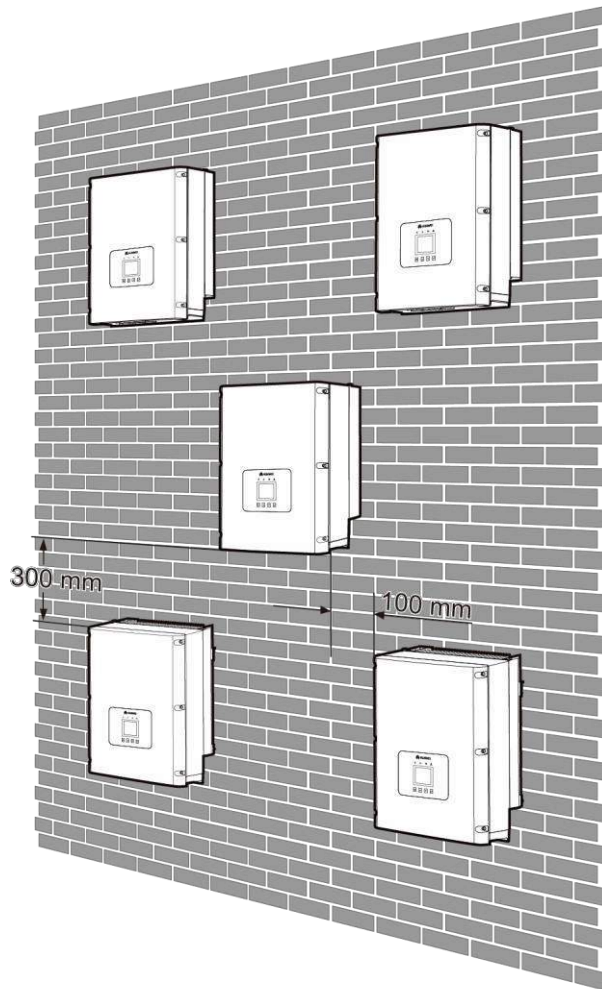

IS01SC0002

Figure 1-6 Stacked installation mode

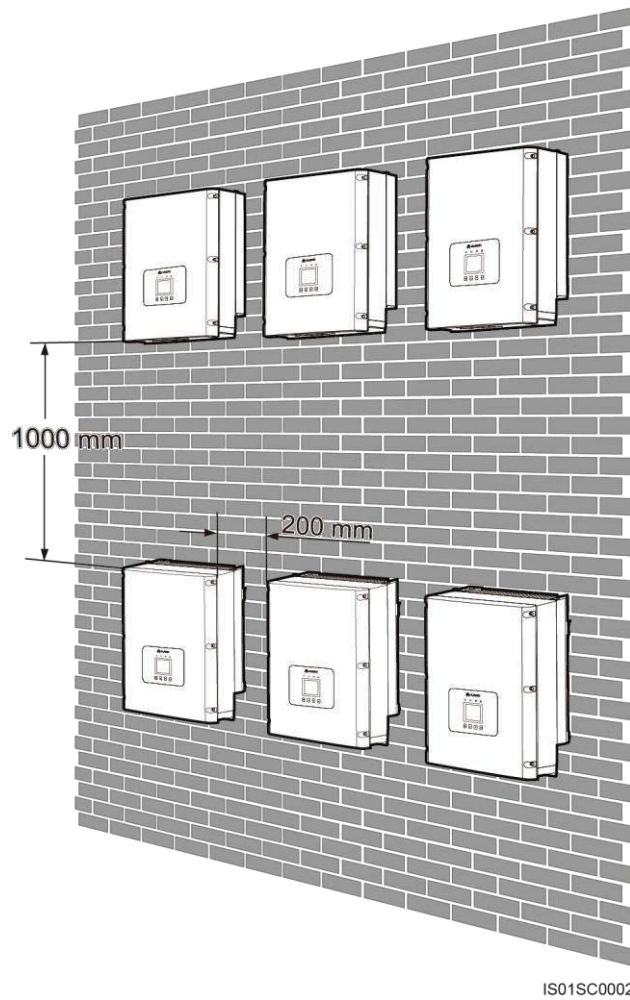

2. Drill holes by using a hammer drill and install expansion bolts, as shown in [Figure 1-8](#). An expansion bolts contains four parts, as shown in [Figure 1-7](#).

Figure 1-7 Expansion bolt composition

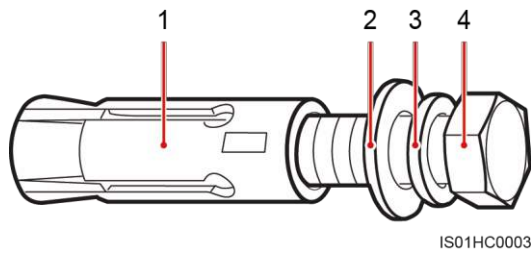

1. Expansion sleeve
2. Flat washer
3. Spring washer
4. M10x60 bolt

Figure 1-8 Drilling a hole and installing an expansion bolt

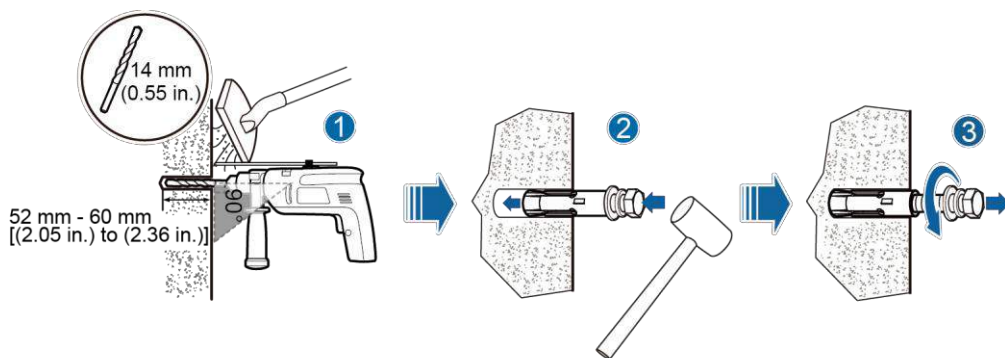

IS01HC0004

Table 1-1 describes the operations shown in Figure 1-8.

Table 1-1 Description

Step	Operation
1	<p>Put a hammer drill with a $\Phi 14$ drill bit on a marked hole position perpendicularly against the wall and drill holes with a depth of 52-60 mm.</p> <p>NOTICE</p> <ul style="list-style-type: none"> To prevent dust inhalation or contact with eyes, wear safety goggles and an anti-dust respirator when drilling holes. Vacuum any dust in or around the holes by using a vacuum cleaner and measure the hole distance. If the holes are inaccurately positioned, drill holes again.
2	<p>Vertically insert an expansion bolt into a hole, and knock the expansion bolt completely into the hole by using a rubber mallet.</p>
3	<p>Remove the M10x60 bolt, spring washer, and flat washer by rotating them counterclockwise.</p> <p>NOTICE</p> <p>Level the front of the expansion sleeve with the concrete wall after removing the bolt, spring washer, and flat washer. Otherwise, the rear panel will not be securely installed on the concrete wall.</p>

- Align the rear panel with hole positions, insert expansion bolts into the holes, and tighten the expansion bolts to a torque of 30 N.m using a torque wrench with a 17 mm open end, as shown in Figure 1-9.

Figure 1-9 Securing a rear panel

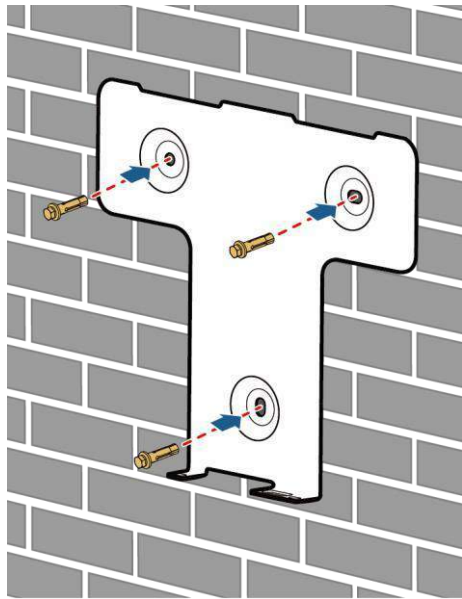

IS01HC0005

Step 2 Install the SUN2000.



NOTE

You are advised to install the SUN2000 in a position in the same height as your eyes to facilitate operation and maintenance.

- If the installation position is low and you can mount the SUN2000 on the rear panel, go to [Step 2.4](#) after performing [Step 2.2](#).
 - If the installation position is high and you cannot mount the SUN2000 on the rear panel, perform [Step 2.1](#) to [Step 2.5](#).
1. Remove the two rubber screws from the top of the SUN2000 using a flat-head screwdriver, and install two M10 lifting eyes, as shown in [Figure 1-10](#).

Figure 1-10 Installing lifting eyes

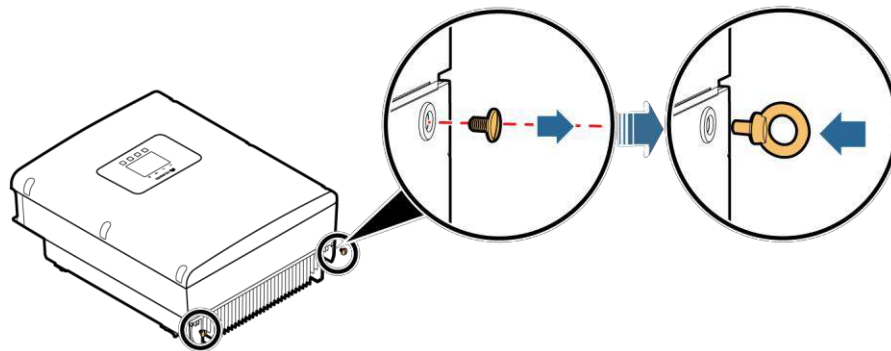

IS01HC0007

2. Use one hand to hold the handle at the bottom of the SUN2000 and use the other hand to hold the handle close to the top of the SUN2000 and then stand the SUN2000, as shown in [Figure 1-11](#). Two peoples are required to install the SUN2000.



NOTICE

To prevent device damage and personal injury, keep balance when lifting the SUN2000 because the SUN2000 has a heavy top.

Figure 1-11 Lifting the SUN2000

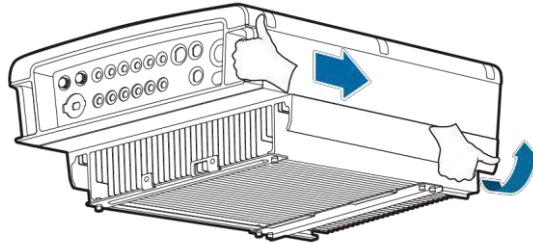

IS01HC0006

3. Route a rope through the lifting eyes and hoist the SUN2000, as shown in [Figure 1-12](#). The rope must bear the SUN2000 weight.



NOTICE

When hoisting the SUN2000, keep balance to protect the SUN2000 from colliding with the wall or other objects.

Figure 1-12 Hoisting the SUN2000

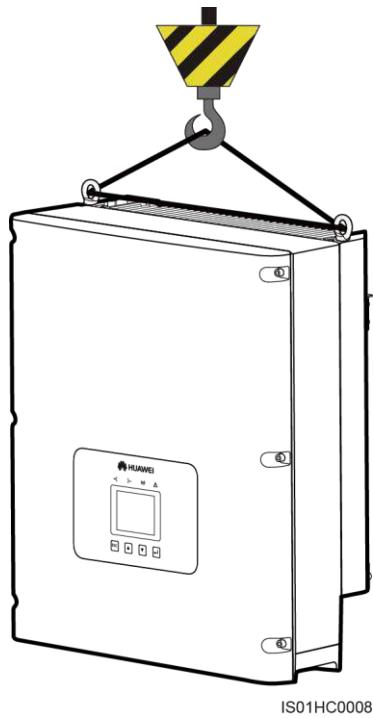

4. Mount the SUN2000 on the rear panel and keep them aligned with each other, as shown in [Figure 1-13](#) and [Figure 1-14](#).

Figure 1-13 Mounting the SUN2000 on the rear panel (front view)

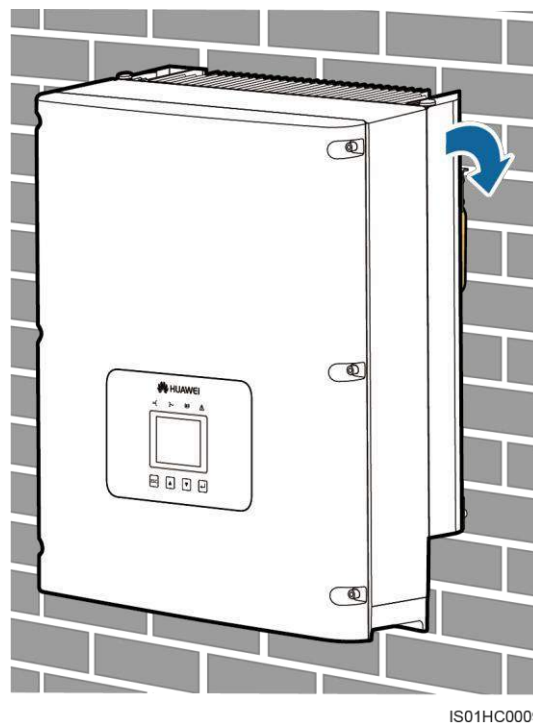
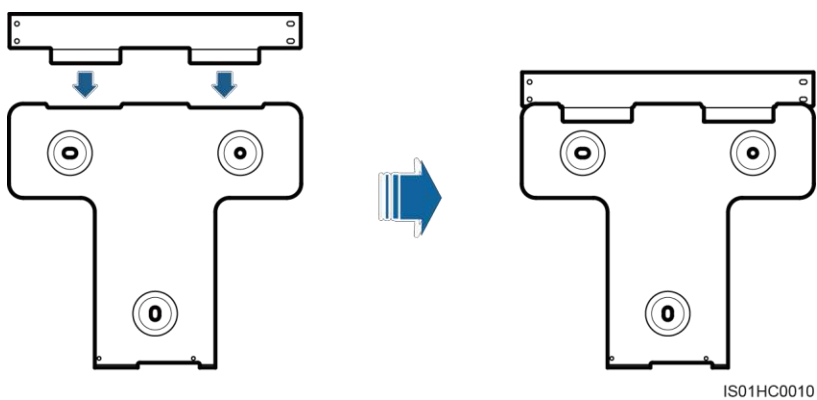

Figure 1-14 Mounting the SUN2000 on the rear panel (rear view)



5. Tighten the two hexagon screws at the bottom the SUN2000 (tightening torque of 5 N.m), and then install an anti-theft lock, as shown in [Figure 1-15](#).

You can secure the SUN2000 to the rear panel and protect it from stealing by installing an anti-theft lock, but this action is optional.

Figure 1-15 Tightening hexagon screws

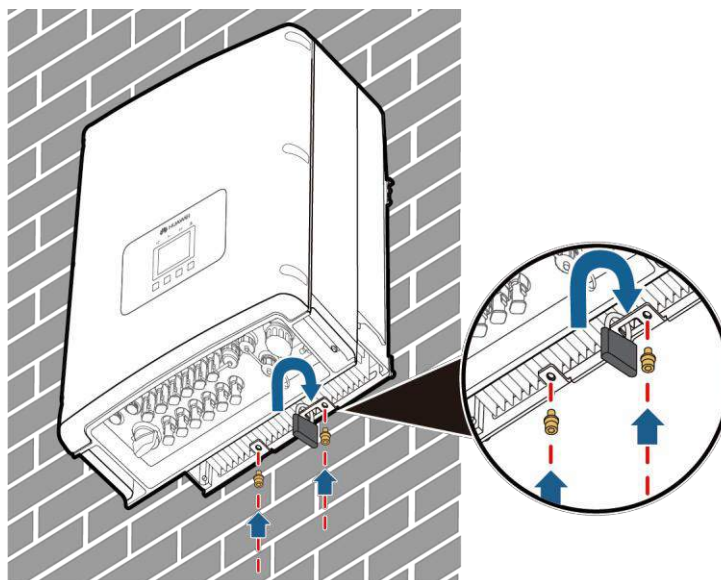

----End

5. Connecting PGND Cables



NOTE

- Good grounding for the SUN2000 can help resist the impact of the surge voltage and improve the EMI performance. First connect the PGND cable before connecting the AC power cable, DC power cable, and communication cable.

For the system with one SUN2000, connect the PGND cable to the ground. For the system with multiple SUN2000s, connect the PGND cables of all SUN2000s to a ground bar in equipotential mode.

- If the installation location is near the ground, first connect the PGND cable to the ground before installing the SUN2000 on the wall.

Step 1 Remove the insulation layer with an appropriate length using a wire stripper, as shown in [Figure 1-16](#).

6 mm² (10 AWG) outdoor power cables are recommended for grounding purposes.

Figure 1-16 Preparing a ground cable (1)

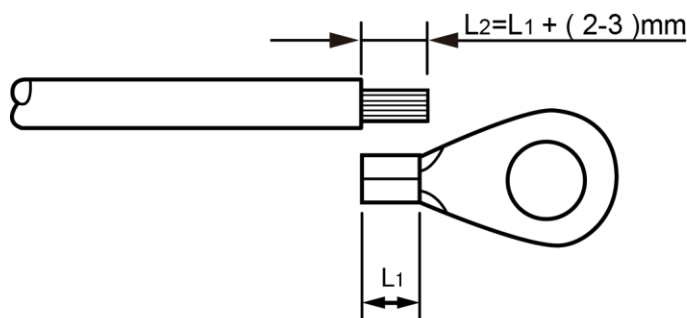

IS01ZC0002

Note: L2 is 2 to 3 mm longer than L1.

Step 2 Insert the exposed core wires into the OT terminal and crimp them by using a crimping tool, as shown in [Figure 1-17](#).

Recommended OT terminals: OT M6; recommended ground cables: with a cross sectional area of larger than or equal to 6 mm².

Figure 1-17 Preparing a ground cable (2)

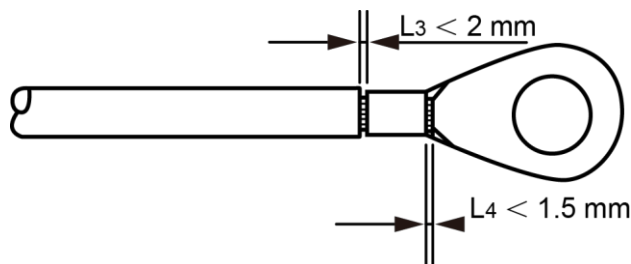

IS01ZC0003

Note 1: L3 is the length between the insulation layer of the ground cable and the crimped part. L4 is the distance between the crimped part and core wires protruding from the crimped part.

Note 2: The cavity formed after crimping the conductor crimp strip shall wrap the core wires completely. The core wires shall contact the terminal closely.

Step 3 Install the crimped OT terminal, flat washer, and spring washer on the M6 welded stud, and tighten the nut to a torque of 5 N.m using a socket wrench.



NOTE

To enhance the anti-corrosion performance of the ground terminals, apply silica gel on them after connecting the ground cable.

----End

6. Connecting AC Output Power Cables

Step 1 Remove the cable gland and the adapter from the AC output connector.

Step 2 Remove the insulation layer of the AC output cable of an appropriate length using a wire stripper.



NOTICE

The three-phase AC input power cables, N cable, and PGND cable must be properly connected. (No N cable connections are involved for the SUN2000-28KTL.)

1. Strip the outer jacket of AC output cable by 55 mm.
2. Strip the insulation layer of each core wires by 12 mm.

Figure 1-18 Connecting an AC output power cable (1) (unit: mm)

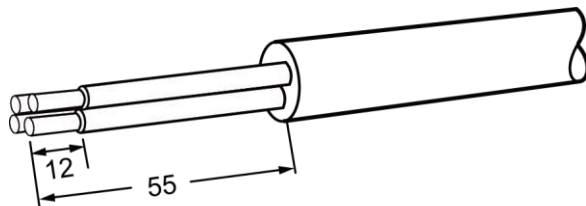

IS012C0005



NOTE

The preceding figure shows only how to strip cables for the SUN2000-8KTL to SUN2000-23KTL. For the SUN2000-28KTL, align the N cable with the protective jacket and cut off the N cable.



CAUTION

When cutting off the cable, take protective measures to prevent the cable from splashing and hurting people.

Step 3 Insert AC output cable (L1, L2, L3 and N) into the cable gland and the adapter, as shown in [Figure 1-19](#) and [Figure 1-20](#).

 **NOTE**
When the outer diameter of the cable is greater than 16 mm, remove a seal ring from the cable gland before inserting the power cable into the cable gland and the adapter.

Figure 1-19 Connecting an AC output power cable (2)

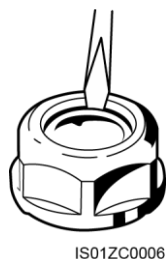
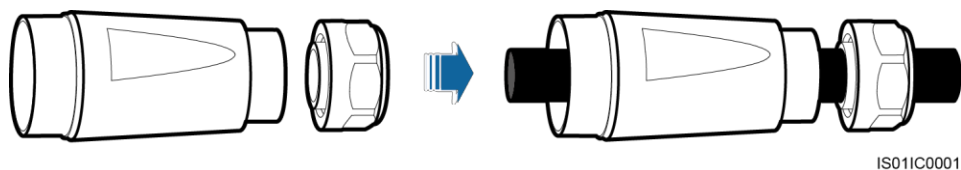

Figure 1-20 Connecting an AC output power cable (3)



Step 4 Loosen the screws inside the coupling nut holes using a flat-head screwdriver, insert the core wires into corresponding holes, and tighten the screws, as shown in [Figure 1-21](#) and [Figure 1-22](#).

Tighten the screws to a torque of 0.7 N.m.

Figure 1-21 Connecting an AC output power cable (4)

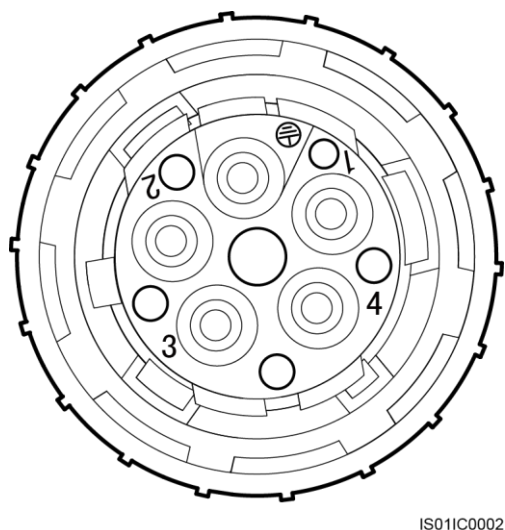

SUN2000 (8KTL-28KTL)
Quick Installation Guide

- Connect L1 to the hole numbered 1.
- Connect L2 to the hole numbered 2.
- Connect L3 to the hole numbered 3.
- Connect N to the hole numbered 4.

For the SUN2000-28KTL, do not connect the N cable to the hole numbered 4.

Figure 1-22 Connecting an AC output power cable (5)

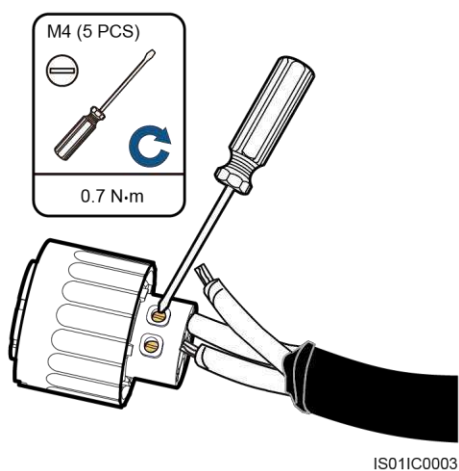

Step 5 Check that all core wires are properly connected, as shown in [Figure 1-23](#).

Figure 1-23 Connecting an AC output power cable (6)

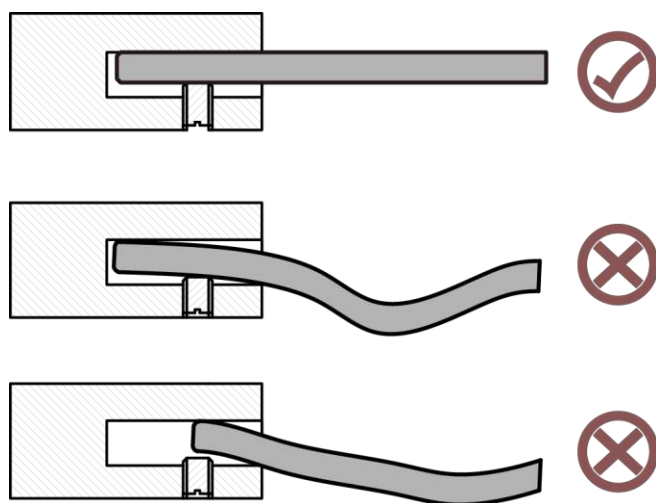

Step 6 Secure the adapter to the coupling nut, as shown in [Figure 1-24](#).

Tighten the adapter to a torque of 1-2 N.m.

Figure 1-24 Connecting an AC output power cable (7)

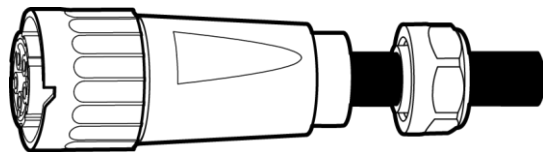

IS011C0004

Step 7 Secure the cable gland to the adapter, as shown in [Figure 1-25](#).

Tighten the cable gland to a torque of 5 N.m (You need to use some tool to achieve this torque).

Figure 1-25 Connecting an AC output power cable (8)

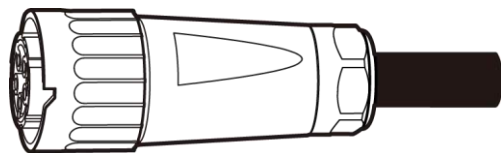

IS011C0005

Step 8 Connect the AC output connector to the bayonet coupling of the AC output wiring terminal on the SUN2000 and rotate it clockwise until you hear a "click" sound, as shown in [Figure 1-26](#).

Because no sufficient space is available on the right of the AC terminal, tighten the terminal using the left hand.

Figure 1-26 Connecting an AC output power cable (9)

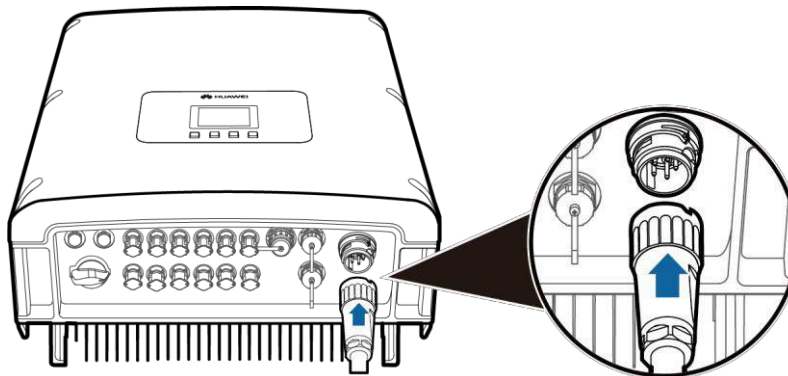

IS011C0006



NOTICE

The AC output connector securely connects to the AC output wiring terminal after the bayonet coupling snaps into place.

----End

7. Connecting DC Input Power Cables

Step 1 Remove cable glands from the positive and negative connectors.

Step 2 Remove the insulation layer with an appropriate length from the positive and negative power cables by using a wire stripper as show in [Figure 1-27](#).

PV power cables with a cross-sectional area of 4 mm² are recommended.



NOTICE

Cables with high rigidity, such as armored cables, are not recommended, because poor contact may be caused by the bending of the cables.

Figure 1-27 Connecting DC input power cables (1)

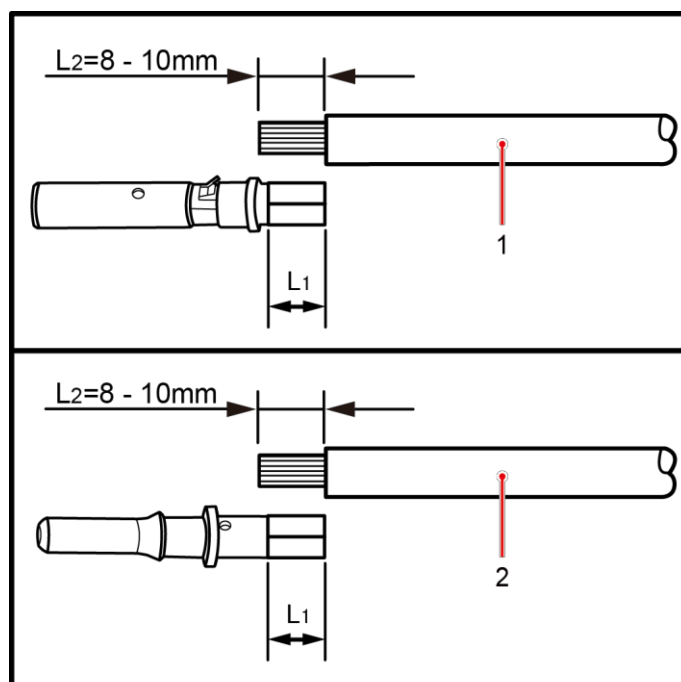

IS01ZC0009

1. Positive power cable

2. Negative power cable

Step 3 Insert the stripped positive and negative power cables into the positive and negative metal terminals respectively and crimp them using a clamping tool. Ensure that the cables are crimped until they cannot be pulled out by force less than 400 N, as shown in [Figure 1-28](#).

Figure 1-28 Connecting DC input power cables (2)

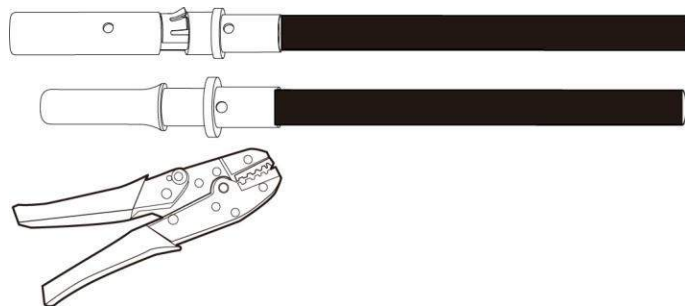

IS01ZC0017

Step 4 Insert crimped power cables into corresponding housings until you hear a "click" sound. The power cables snap into place, as shown in [Figure 1-29](#).

Figure 1-29 Engaging metal terminals

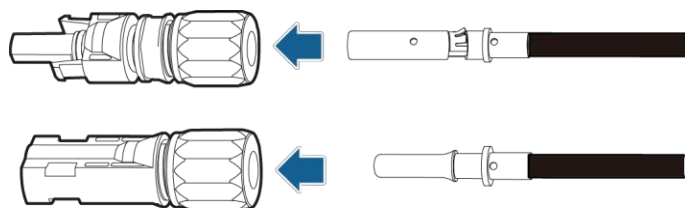

IS01ZC0018



NOTICE

Insert the crimped positive and negative power cables into the corresponding insulation covers. Check that the cables are in position by slightly pulling them back.

Step 5 Reinstall cable glands on positive and negative connectors and rotate them against the insulation covers.

It is recommended that you secure the nut by using removal wrenches, as shown in [Figure 1-30](#).

Figure 1-30 Connecting DC input power cables (3)

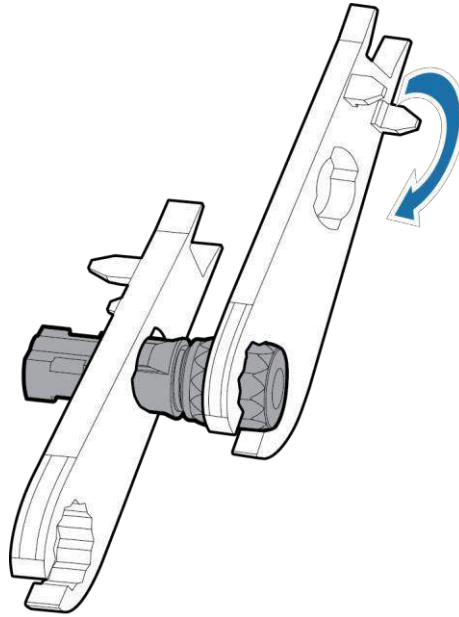

IS011C0016

Step 6 Take off the blue dustproof plugs from the bottom of the DC input connectors.

Before performing step 8, the DC switch is **OFF**

Step 7 Insert the positive and negative connectors into corresponding DC input terminals of the SUN2000 until you hear a "click" sound, as shown in [Figure 1-31](#).

Figure 1-31 Connecting DC input power cables (4)

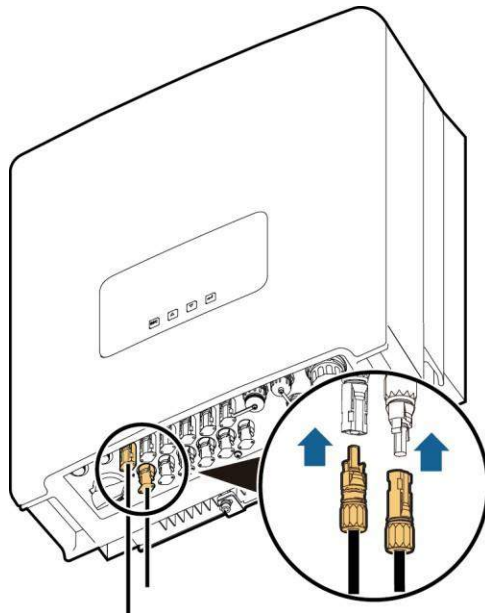

IS011C0028



NOTICE

After the positive and negative connectors are in position, the clearance between the DC terminals and connectors should be less than or equal to 0.8 mm.

----End

8. Connecting RS485 Communications Cables

Step 1 Remove the insulation layer of an appropriate length from the shielded network cable using a wire stripper.

You are recommended to use 24 AWG outdoor shielded network cables with the internal resistance less than or equal to 1.5 ohms/10 m and external diameter of 4.5 mm to 7.5 mm as RS485 communications cables.

Step 2 Insert the shielded network cable into the sealing nut, seals, screw nut, and housing.

Step 3 Connect the stripped network cable to corresponding pins on the plug, as shown in [Figure 1-33](#).

Figure 1-32 Connecting a communications cable (1)

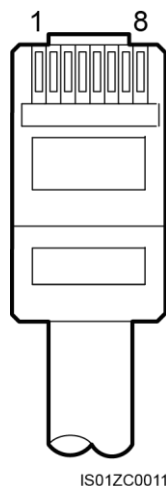

[Figure 1-32](#) shows the side without a clip.

[Table 1-2](#) lists the cable colors and functions.

Table 1-2 Cable colors and functions

No.	Color	Function
1	White and orange	RS485A, RS485 differential signal +
2	Orange	RS485B, RS485 differential signal -

SUN2000 (8KTL-28KTL)
Quick Installation Guide

No.	Color	Function
3	White and green	PGND
4	Blue	RS485A, RS485 differential signal +
5	White and blue	RS485B, RS485 differential signal -
6	Green	PGND
7	White and brown	PGND
8	Brown	PGND

Figure 1-33 Connecting a communications cable (2)

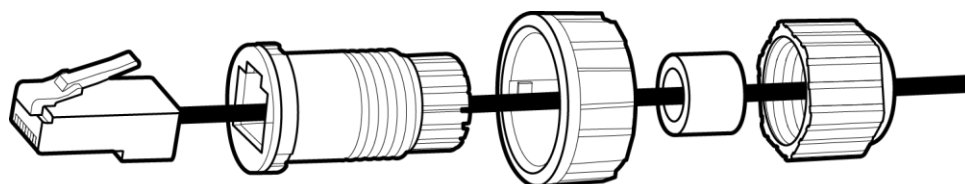

IS01IC0011

Step 4 Crystal plug with RJ11 crimping tool.

Step 5 Secure the housing to the plug, as shown in Figure 1-34.

Figure 1-34 Connecting a communications cable (3)

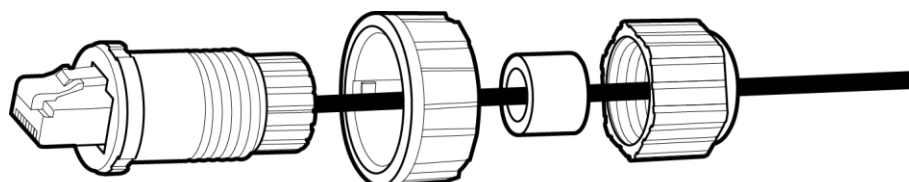

IS01IC0012

Step 6 Insert the seals into and secure the screw nut to the housing, as shown in Figure 1-35.

Figure 1-35 Connecting a communications cable (4)

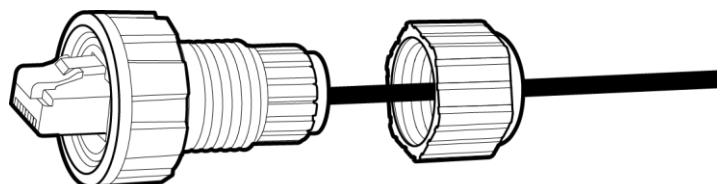

IS01IC0013

Step 7 Secure the sealing nut to the housing, as shown in [Figure 1-36](#).

Figure 1-36 Connecting a communications cable (5)

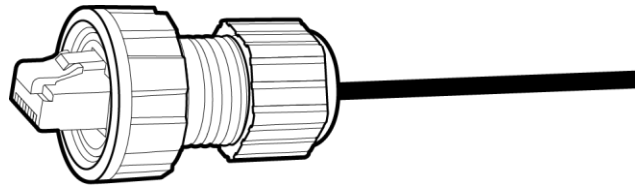

IS011C0014

Step 8 Insert the plug into the RS485 port on the SUN2000, and tighten the screw nut.

----End

9. Powering on the SUN2000

Step 1 Check that the SUN2000 is installed on the wall correctly and securely.

For details, see [4 Installing the SUN2000](#).

Step 2 Check that all AC output power cables are properly connected.

For details, see [6 Connecting AC Output Power Cables](#).

Step 3 Check that all DC input power cables are properly connected.

For details, see [7 Connecting DC Input Power Cables](#).

Step 4 Ensure that unused DC input terminals are sealed.

Step 5 Switch on the AC circuit breaker between the SUN2000 and the power grid.



NOTICE

If you perform [Step 6](#) before [Step 5](#), the SUN2000 generates an abnormal shutdown alarm. You can start the SUN2000 only after faults are automatically rectified. The default alarm clearance time is 5 minutes. You can modify the time over the EMS software of the PC terminal.



NOTE

The monitoring panel can be activated only after power is supplied to the DC or AC side.

Step 6 Ensure that the **DC SWITCH** at the bottom of the SUN2000 is **ON**.



Step 7 (Optional) Measure the temperatures at the joints between the DC terminals and the connectors by using a point thermometer.



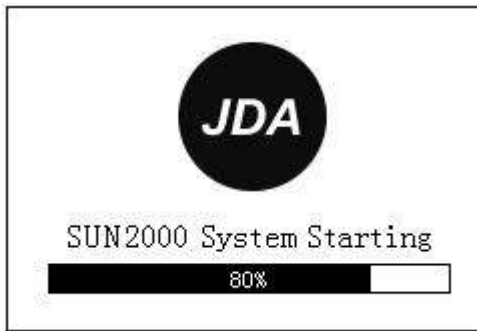
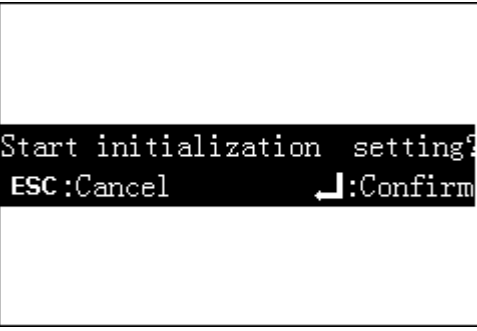

----End

10. Setting Initialization Parameters

Procedure

- The following table describes the process for setting initialization parameters. The parameter values in the figures are for reference only.

LCD	Operation Procedure
	<p>1. After startup, the SUN2000 enters the initialization page.</p> <p>The default system language is English.</p>
	<p>2. Press ↓ to enter the Wizard page.</p> <p>To return to the default page, press ESC. To reset initialization parameters in the future, choose Settings > Wizard as Advanced User.</p>
	<p>3. After selecting a display language, click ↓.</p> <p>The pages will be displayed in the selected language.</p>
	<p>4. After setting the correct date and time, click ↓.</p> <ul style="list-style-type: none"> To select the parameter, click ↓. To set the parameter value, set ▲ or ▼. The date is displayed in the format of YYYY-MM-DD. The time is displayed in the format of hh-mm-ss, in which hh, mm, and ss stand for hour, minute, and second respectively.

LCD	Operation Procedure
<pre> Initialization->Wizard Grid Code VDE-AR-N4105 CGC/GF004:2011 VDE-0126-1-1-FR-A VDE-0126-1-1-FR-B VDE-0126-1-1-FR-C VDE-0126-1-1-BU </pre>	<p>5. After setting the power grid standard code, click .</p> <p>To select a power grid standard code, click  or .</p> <p>NOTICE Correctly set Grid Code. Otherwise, the inverters cannot normally start.</p> <p>NOTE</p> <ul style="list-style-type: none"> When the illumination is weak, the grid code cannot be successfully set. Wait until the illumination becomes sufficient, log in to the system as Advanced User, and choose Settings > Init Wizard to set the grid code. The SUN2000-28KTL applies only to the medium-voltage grid-feeding scenarios. The power grid standard codes supported are the China medium-voltage grid standard code, Germany medium-voltage grid standard code, and user-defined medium-voltage grid standard code.
<pre> Initialization->Wizard Finished Language:English Time:2012-01-01 00:38:06 Grid Code:VDE-AR-N4105 </pre> <p style="text-align: right;">:Confirm</p>	<p>6. On the Finished page, click .</p>



NOTICE

For multiple SUN2000s networked, after the initialization parameters are set, you need to set the address and baud rate for each SUN2000 by following the rules below:

- Addresses for all SUN2000s in the same daisy chain should be different from each other. Addresses of all devices in the daisy chain should be in the scope of the SmartLogger address and different from each other, if communication with the SmartLogger is required.
- Baud rates of all SUN2000s in the same daisy chain should be the same. Baud rates of all devices in the daisy chain should be consistent with that of the SmartLogger, if communication with the SmartLogger is required.

----End